



## B300WOA

### Fender Mounting Instructions for MIN300, MIN318 & 1021/202/302 Fenders

#### STEP 1

- A. Unpack all cartons and lay out parts.
- B. Compare the parts with the hardware kit B300WOA as shown in Figure 1.

No.	Description	QTY
PB5010	Steel Weld-On Tapered Bracket	4
I31C100BSF/RBZ	5/16-18 X 1 HEX WASHER HEAD BL	24
I31CNCF/RBZ	5/16-18 CLASS F FLANGE LOCK	24
I31N150WFEZ	5/16 X 1 1/2 FENDER WASHER	24
PB2011	Steel Weld-On Center Bkt	4
I31C100BSF/RBZ	5/16-18 X 1 HEX WASHER HEAD BL	32
I31CNCF/RBZ	5/16-18 CLASS G FLANGE LOCK	32
I31N150WFEZ	5/16 X 1 1/2 FENDER WASHER	32



Figure 1

#### STEP 2

- A. Lay the fenders out and clamp them together (Figure 2). This will make bolting them together much easier.



Figure 2

B. The lip of both fenders needs to be cut off to accommodate the center support bracket (PB2011).

- a. This will be the side of the fenders that is closest to the truck frame.
- b. Place a mark 3" in from the end of each fender (Figure 3).



Figure 3

C. Draw outline of the area that needs to be cut out similar to Figure 4.

- a. Cut out the marked off area.

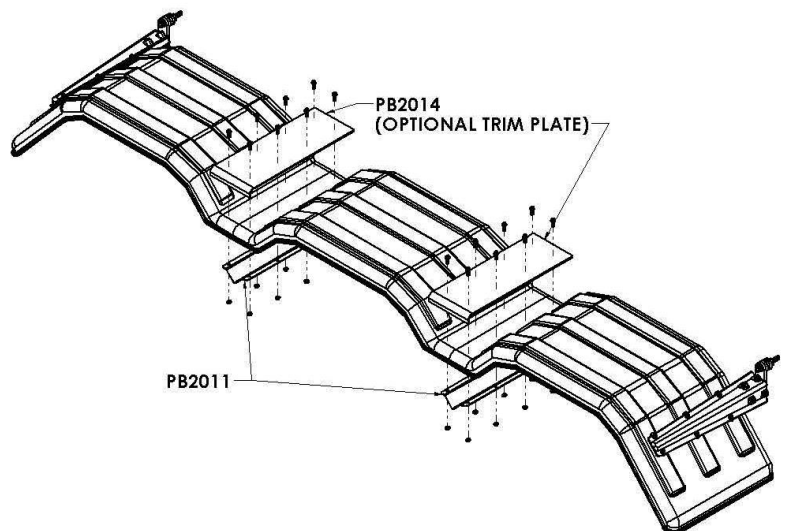

Figure 4

D. Make sure the center bracket and trim plate (if purchased) are centered between the two fenders (Figure 5).

**Tip:** The center bracket (PB2011) v should be facing down.

- a. Drill eight holes through fender and trim plate from the bottom using the holes in the center bracket (PB2011) as a guide.
- b. Use eight 5/16" x 1" bolts to bolt the fenders, trim plate, and center bracket together.
- c. Use eight 5/16" nuts provided with the kit on the underside of the fenders.
- d. Recommended torque is 10-15 ft-lbs.



**Tip:** Start with the bolts closest to the truck frame and work towards the outside.

### **STEP 3**

- A. Measure the suspension travel. This measurement is used to determine the distance between the fender and the wheel.
  - a. For air suspension systems, let the air out of the air bags.
  - b. For spring systems, measure from the stops on the springs to the bottom of the frame.

**NOTE: For air suspensions with travel exceeding 6”:**

In some cases a travel stop may need to be installed to prevent such large gaps between the fenders & tires. This will help with alignment and 5<sup>th</sup> wheel plate clearance. (Please call *Minimizer @ 800-248-3855* for questions regarding this issue).

- B. Gap the fenders  $\frac{3}{4}$ ” over the maximum travel point of the suspension system. The goal is to make sure the fender does not rub on the tire. A gap larger than  $\frac{3}{4}$ ” may be necessary if using worn tires.

**TIP:** Establish the  $\frac{3}{4}$ ” minimum gap required in Step 3B.

- a. For an air suspension system, place a  $\frac{3}{4}$ ” board on top of the tires after the air has been let out of the airbags (Figure 2). Place the fender on top of the board.
- b. For a spring suspension system, add  $\frac{3}{4}$ ” to the measurement from Step 3A.

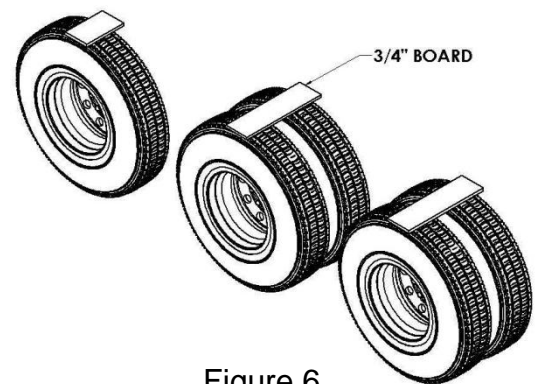

Figure 6

### **STEP 4**

- A. Position the fenders exactly where they will be mounted.
  - a. Visually pick and mark the locations that the brackets will attach to the frame.
- B. It is possible to bolt a plate (not supplied) to the frame and weld the brackets to that plate (Figure 7). Another option is to weld the bracket directly to the frame.
  - a. Plate should be a minimum of  $\frac{1}{4}$ ” thick steel.

**Tip: Check owner’s manual before welding directly to the frame. Most manufacturers do not suggest welding anything directly to the frame.**

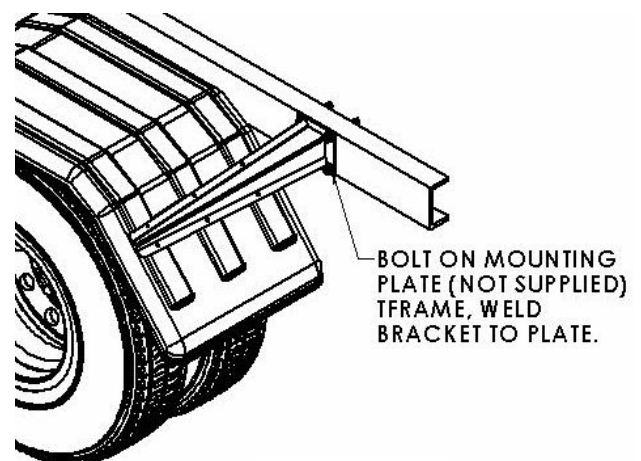

Figure 7

- C. Make sure the brackets are within 10” of the bottom of

the fender to avoid wind blowing the fender back into the tire (Figure 8).

**Tip:** If the front fender bracket is mounted higher than 10", run a piece of steel strapping on the inside of the fender to give it extra strength.

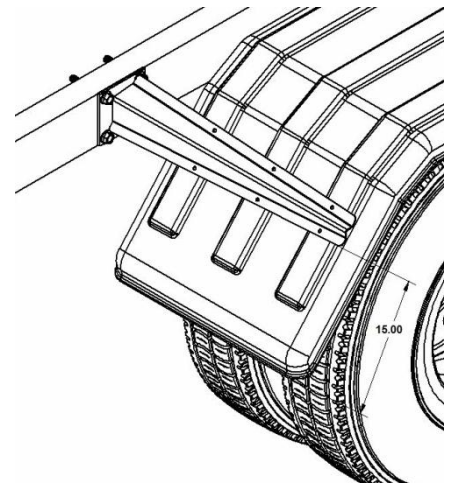

Figure 8

## **STEP 5**

- A. The center bracket PB2011 will be welded to the truck frame. It is possible to bolt a plate (not supplied) to the frame and weld the brackets to that plate (Figure 9). Another option is to weld the bracket directly to the frame.
- Plate should be a minimum of 1/4" thick steel.
  - Suggested plate dimensions are 8" x 8" x 1/4".

**Tip: Check owner's manual before welding directly to the frame. Most manufacturers do not suggest welding anything directly to the frame.**

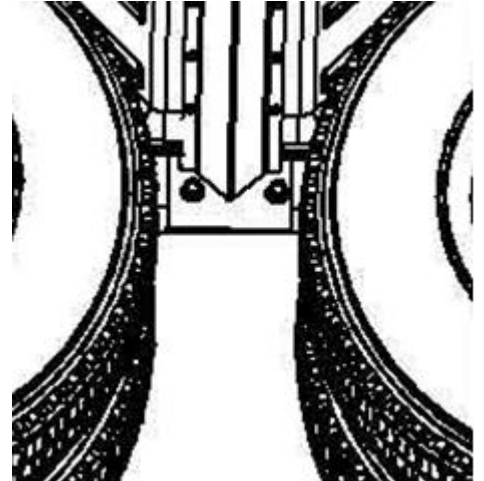

Figure 9

## **STEP 6**

- A. Attach the bracket (PB5010) to the fender.
- Drill six 5/16" holes through the fender using the holes in bracket PB5010 as a guide.
  - Install the 5/16" x 1" bolts through the bracket and into the fender.
  - Use six 5/16" body washers and 5/16" nuts provided with the kit on the underside of the fender.
  - Tighten the 5/16" bolts. Recommended torque is 10-15 ft-lbs.**
  - Make sure the fenders are square and aligned (Figure 10). Twists or bows in the fender will fatigue the material over time.

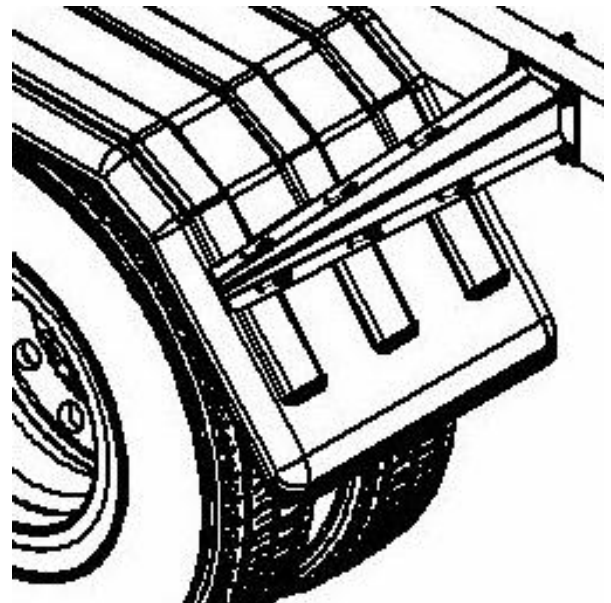

Figure 10

## **STEP 7**

For trucks with air suspension, raise and lower the suspension one final time to confirm that there is adequate clearance between the fenders and wheels.