



## B200WOA

### Fender Mounting Instructions for MIN200 Fenders

#### STEP 1

- A. Unpack all cartons and lay out parts.
- B. Compare the parts with hardware kit B200WOA as shown in Figure 1.

B200WOA Mounting Kit

| PARTNUMBER     | DESCRIPTION                       | QTY. |
|----------------|-----------------------------------|------|
| PB5010         | 5010 TAPERED BRACKET              | 4    |
| 131C100BSF/RBZ | 5/16-18 X 1 HEX WASHER<br>HEAD BL | 40   |
| 131N150WFEZ    | 5/16 X 1 1/2 FENDER WASHER        | 40   |
| 131CNCF/RBZ    | 5/16-18 CLASS G FLANGE<br>LOCK    | 40   |
| PB2011         | STEELE WELD ON BKT                | 2    |



Figure 1

#### STEP 2

- A. Lay the fenders out and clamp them together (Figure 2). This will make bolting them together much easier.

Figure 2



- B. The lip of both fenders needs to be cut off to accommodate the center support bracket (PB2011).
  - a. This will be the side of the fenders that is closest to the truck frame.
  - b. Place a mark 3" in from the end of each fender (Figure 3).



Figure 3

- C. Draw outline of the area that needs to be cut out similar to Figure 4.
  - a. Cut out the marked off area.



Figure 4

- D. Make sure the center bracket and trim plate (if purchased) are centered between the two fenders (Figure 5).

**Tip:** The center bracket (PB2011) v should be facing down.

- a. Drill eight holes through fender and trim plate from the bottom using the holes in the center bracket (PB2011) as a guide.
- b. Use eight 5/16" x 1" bolts to bolt the fenders, trim plate, and center bracket together.
- c. Use eight 5/16" nuts provided with the kit on the underside of the fenders.

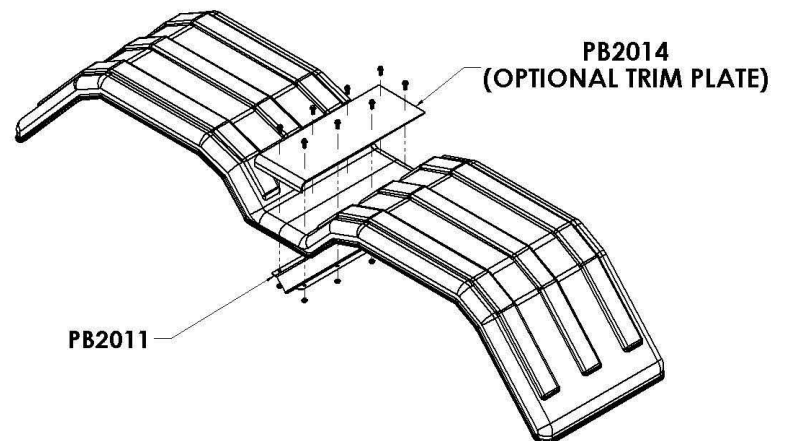

Figure 5

- d. **Recommended torque is 10-15 ft-lbs.**

**Tip:** Start with the bolts closest to the truck frame and work towards the outside.

### **STEP 3**

- A. Measure the suspension travel. This measurement is used to determine the distance between the fender and the wheel.
- For air suspension systems, let the air out of the air bags.
  - For spring systems, measure from the stops on the springs to the bottom of the frame.

**NOTE: For air suspensions with travel exceeding 6":**

In some cases a travel stop may need to be installed to prevent such large gaps between the fenders & tires. This will help with alignment and 5<sup>th</sup> wheel plate clearance. (Please call *Minimizer @ 800-248-3855* for questions regarding this issue).

- B. Gap the fenders  $\frac{3}{4}$ " over the maximum travel point of the suspension system. The goal is to make sure the fender does not rub on the tire. A gap larger than  $\frac{3}{4}$ " may be necessary if using worn tires.

**TIP:** Establish the  $\frac{3}{4}$ " minimum gap required in Step 3B.

- For an air suspension system, place a  $\frac{3}{4}$ " board on top of the tires after the air has been let out of the airbags (Figure 6). Place the fender on top of the board.
- For a spring suspension system, add  $\frac{3}{4}$ " to the measurement from Step 3A.

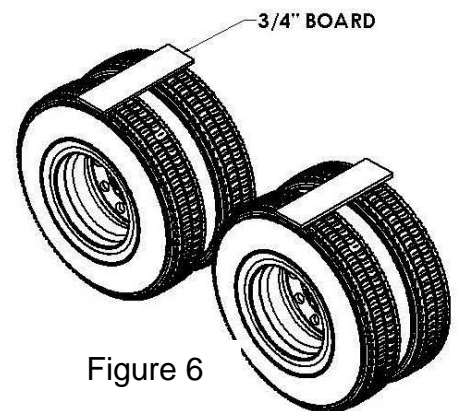

Figure 6

### **STEP 4**

- A. Position the fenders exactly where they will be mounted.
- Visually pick and mark the locations where the brackets will attach to the frame.
- B. It is possible to bolt a plate (not supplied) to the frame and weld the brackets to that plate (Figure 7). Another option is to weld the bracket directly to the frame.

- Plate should be a minimum of  $\frac{1}{4}$ " thick steel.

**Tip: Check owner's manual before welding directly to the frame. Most manufacturers do not suggest welding anything directly to the frame.**

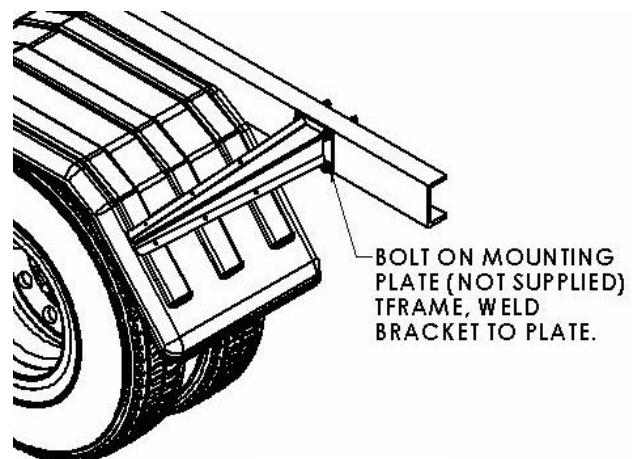

Figure 7

- B. If possible, position the mounting brackets so they are located within 15" of the bottom of the fender. This protects against wind blowing the leading edge of the fender back into the tire (Figure 8).

**Tip:** If the front fender bracket is mounted higher than 15", refer to <http://www.minimizer.com/instructions.html> for further suggestions on adding additional support.

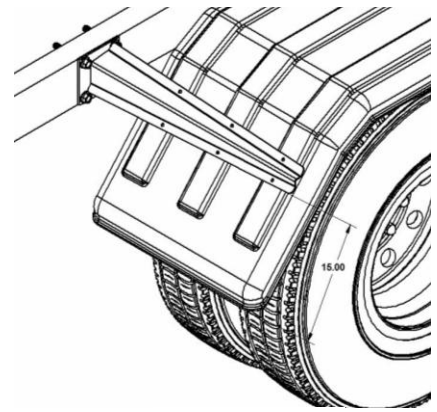

Figure 8

## **STEP 5**

- A. The center bracket PB2011 will be welded to the truck frame. It is possible to bolt a plate (not supplied) to the frame and weld the brackets to that plate (Figure 9). Another option is to weld the bracket directly to the frame.

- a. Plate should be a minimum of 1/4" thick steel.
- b. Suggested plate dimensions are 8" x 8" x 1/4".

**Tip: Check owner's manual before welding directly to the frame. Most manufacturers do not suggest welding anything directly to the frame.**

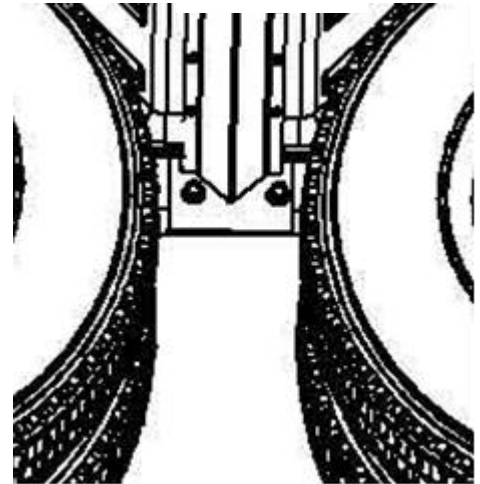

Figure 9

## **STEP 6**

- A. Attach the bracket (PB5010) to the fender.
- a. Drill six 5/16" holes through the fender using the holes in bracket PB5010 as a guide.
  - b. Install the 5/16" x 1" bolts through the bracket and into the fender.
  - c. Use six 5/16" fender washers and 5/16" nuts provided with the kit on the underside of the fender.
  - d. **Tighten the 5/16" bolts. Recommended torque is 10-15 ft-lbs.**
  - e. Make sure the fenders are square and aligned (Figure 10). Twists or bows in the fender will fatigue the material over time.

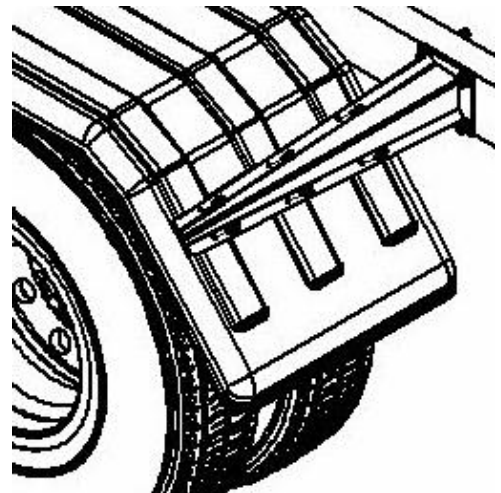

Figure 10

## **STEP 7**

For trucks with air suspension, raise and lower the suspension one final time to confirm that there is adequate clearance between the fenders and wheels.