



B200BTPA

Fender Mounting Instructions for MIN200 Fenders

STEP 1

- A. Unpack all cartons and lay out parts.
- B. Compare the parts with hardware kit B200BTPA as shown in Figure 1.

B200BTPA Mounting Kit

PART NUMBER	DESCRIPTION	QTY.
PB501026	26.5 COMPOSIT TAPERED BKT.	4
PBLOCK	BACK BLOCK FOR PLASTIC TAPERED	4
I31C300BSF/RBZ	5/16- 18 X 3 HEX WASH HEAD B	16
I31C100BSF/RBZ	5/16-18 X 1 HEX WASHER HEAD BL	40
I31N150WFEZ	5/16 X 1 1/2 FENDER WASHER	40
I31CNCN/RBZ	5/16-18 CLASS G FLANGE LOCK	56
PB5015	SWIVEL BRACKET BLACK Z	4
I62C450BFL8/RB2FT	5/8"-11 x 4 1/2" HEX FLANGE BOLT	4
I62CNCN/RB2	5/8"-11 CLASS G FLANGE LOCK N	4
PB1/2"SPACER	1/2" POLY SPACER	12
PB2011	STEELE WELD ON BKT	2



Figure 1

STEP 2

- A. Lay the fenders out and clamp them together (Figure 2). This will make bolting them together much easier.



Figure 2

- B. The lip of both fenders needs to be cut off to accommodate the center support bracket (PB2011).
 - a. This will be the side of the fenders that is closest to the truck frame.
 - b. Place a mark 3" in from the end of each fender (Figure 3).



Figure 3

- C. Draw outline of the area that needs to be cut out similar to Figure 4.
 - a. Cut out the marked off area.



Figure 4

- D. Make sure the center bracket and trim plate (if purchased) are centered between the two fenders (Figure 5).

Tip: The center bracket (PB2011) v should be facing down.

- a. Drill eight holes through fender and trim plate from the bottom using the holes in the center bracket (PB2011) as a guide.
- b. Use eight 5/16" x 1" bolts to bolt the fenders, trim plate, and center bracket together.
- c. Use eight 5/16" nuts provided with the kit on the underside of the fenders.

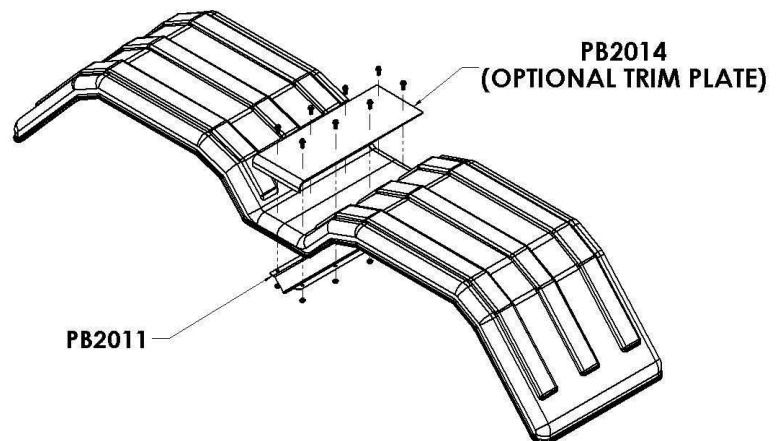

Figure 5

- d. **Tighten the 5/16" x 1" bolts to a recommended torque of 10-15 ft-lbs.**

Tip: Start with the bolts closest to the truck frame and work towards the outside.

STEP 3

- A. Measure the suspension travel. This measurement is used to determine the distance between the fender and the wheel.
 - a. For air suspension systems, let the air out of the air bags.
 - b. For spring systems, measure from the stops on the springs to the bottom of the frame.

NOTE: For air suspensions with travel exceeding 6”:

In some cases a travel stop may need to be installed to prevent such large gaps between the fenders & tires. This will help with alignment and 5th wheel plate clearance. (Please call *Minimizer @ 800-248-3855* for questions regarding this issue).

- B. Gap the fenders $\frac{3}{4}$ ” over the maximum travel point of the suspension system. The goal is to make sure the fender does not rub on the tire. A gap larger than $\frac{3}{4}$ ” may be necessary if using worn tires.

TIP: Establish the $\frac{3}{4}$ ” minimum gap required in Step 3B.

- a. For an air suspension system, place a $\frac{3}{4}$ ” board on top of the tires after the air has been let out of the airbags (Figure 6). Place the fender on top of the board.
- b. For a spring suspension system, add $\frac{3}{4}$ ” to the measurement from Step 3A.

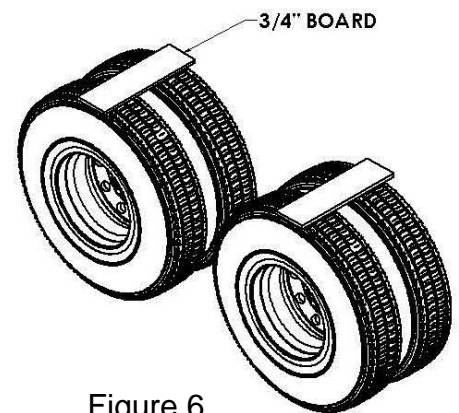

Figure 6

STEP 4

- A. Position the fenders exactly where they will be mounted.
 - a. Visually pick and mark the locations that the brackets will bolt to the frame.
- B. Try to use existing holes in the frame to bolt through. It is possible to remove any existing frame bolt and replace it with the supplied bolt in the bracket kit.

Tip: It is common for the front bracket to align with the existing quarter fender holes and the rear bracket to align with the holes left from the mud flap hanger.



- C. Spacers are supplied to bring the steel swivel away from the frame in the event of any obstructions (Figure 7).
 - a. The ideal setup is to mount the steel swivel directly to the frame.

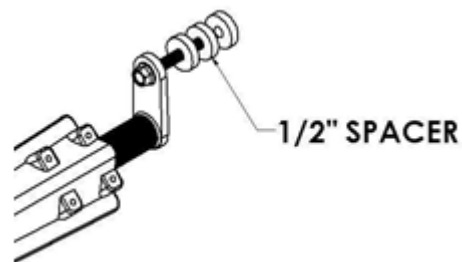

Figure 7

NOTE: Use spacers only when necessary.

- D. If possible, position the mounting brackets so they are located within 15" of the bottom of the fender. This protects against wind blowing the leading edge of the fender back into the tire (Figure 8).

Tip: If the front fender bracket is mounted higher than 15", refer to <http://www.minimizer.com/instructions.html> for further suggestions on adding additional support.

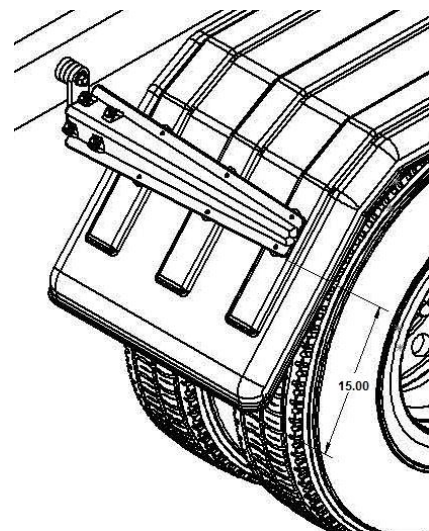

Figure 8

STEP 5

- A. Use four 5/16" x 3" bolts to attach the bracket (part number PB501026) and the backing block (part number PBLOCK) to the steel swivel (part number PB5015). See Figure 9.

Tip: Do not use tools at this point to tighten the bolts. This will allow the bracket to rotate on the swivel during installation.

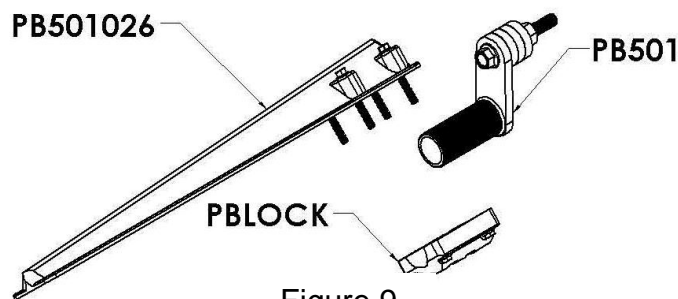

Figure 9

TIP: USE CARE WITH POWER TOOLS AS OVER-TORQUING WILL CAUSE CRACKS IN THE BRACKET. RECOMMENDED TORQUE IS 10-15 ft-lbs.

NOTE: DO NOT EXCEED RECOMMENDED TORQUE. THIS WILL VOID THE WARRANTY.

TIP: Do not completely tighten one side of the backing block before moving to the other side. Alternate tightening of bolts as pictured in Figure 10. Make sure to only tighten halfway and then repeat the pattern in Figure 10 until backing block is flush against the bracket (PB501026).

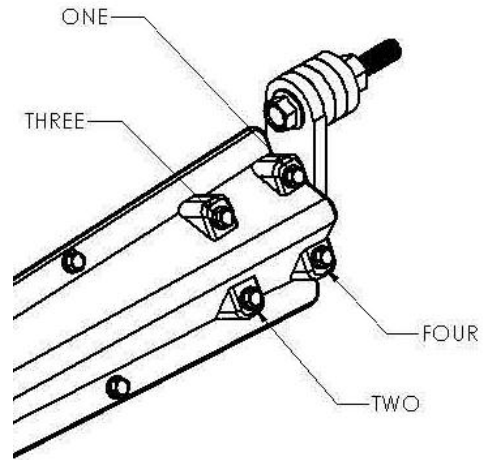

Figure 10

STEP 5

- A. Once the brackets are placed in position with the fender, tighten the 5/8" x 4-1/2" bolts that go through the PB5015 steel swivel to attach the swivel securely to the frame (Figure 11). **Recommended torque is 160-170 FT-LBS**

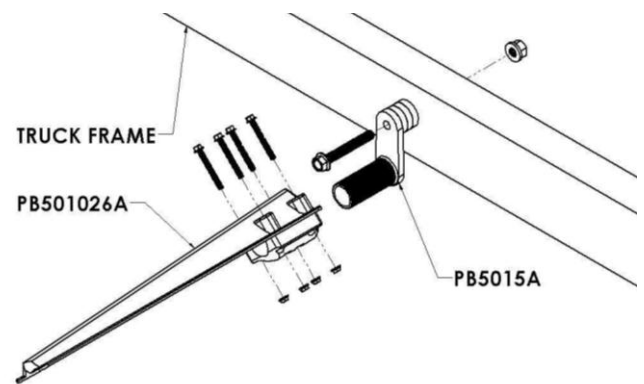

Figure 11

STEP 7

- A. The center bracket PB2011 will be attached to the truck frame. It is possible to bolt a plate (not supplied) to the frame and weld the brackets to that plate (Figure 12). Another option is to weld the bracket directly to the frame.

- a. Plate should be a minimum of 1/4" thick steel.
- b. Suggested plate dimensions are 8" x 8" x 1/4".

Tip: Check owner's manual before welding directly to the frame. Most manufacturers do not suggest welding anything directly to the frame.

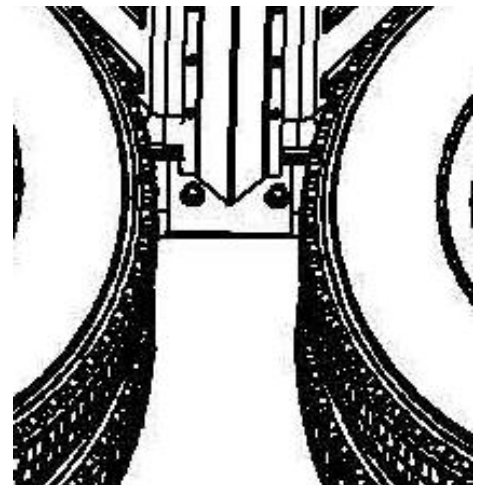

Figure 12

STEP 8

A. Attach the bracket (PB501026A) to the fender.

- a. Drill six 5/16" holes through the fender using the holes in bracket PB501026A as a guide.
- b. Install the 5/16" x 1" bolts through the bracket and into the fender.
- c. Use six 5/16" fender washers and 5/16" nuts provided with the kit on the underside of the fender.
- d. **Tighten the bolts to recommended torque of 10-15 FT-LBS.** Hand tightening with a torque wrench is recommended. **DO NOT EXCEED RECOMMENDED TORQUE.**
- e. Make sure the fenders are square and aligned (Figure 13). Twists or bows in the fender will fatigue the material over time.

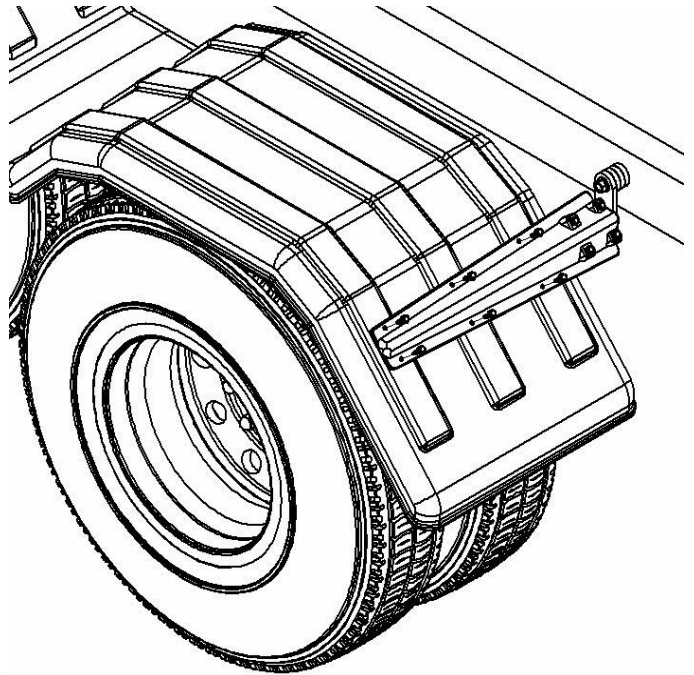

Figure 13

STEP 9

- A. For trucks with air suspension, raise and lower the suspension one final time to confirm that there is adequate clearance between the fenders and wheels.
- B. Recheck all brackets and bolts to ensure they are tightened to the recommended torque.

NOTE: ONCE FENDERS ARE IN SERVICE OCCASIONALLY CHECK TORQUE ON 5/8" X 4-1/2" HEX BOLTS IN THE FRAME TO MAKE SURE THEY DO NOT LOOSEN OVER TIME.