



B100WOA

Fender Mounting Instructions for MIN100, MIN150, MIN1600, MIN161200, MIN1900, MIN2200, MIN2218, MIN2260, MIN2480 & MIN9950 Fenders

STEP 1

- A. Unpack all cartons and lay out parts.
- B. Compare the parts with the hardware kit B100WOA as shown in Figure 1.

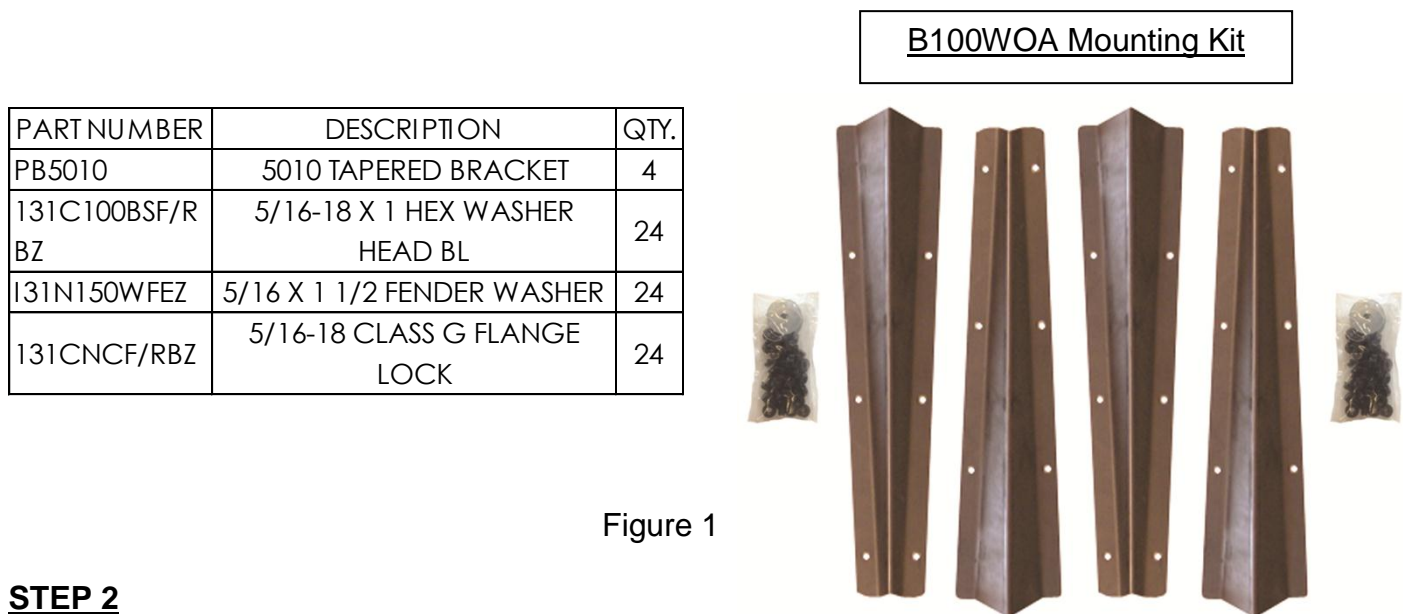

Figure 1

STEP 2

- A. Measure the suspension travel. This measurement is used to determine the distance between the fender and the wheel.
 - a. For air suspension systems, let the air out of the air bags.
 - b. For spring systems, measure from the stops on the springs to the bottom of the frame.

NOTE: For air suspensions with travel exceeding 6”:

In some cases a travel stop may need to be installed to prevent such large gaps between the fenders & tires. This will help with alignment and 5th wheel plate clearance. (Please call Minimizer @ 800-248-3855 for questions regarding this issue).

- B. Gap the fenders $\frac{3}{4}$ ” over the maximum travel point of the suspension system. The goal is to make sure the fender does not rub on the tire. A gap larger than $\frac{3}{4}$ ” may be necessary if using worn tires.

TIP: Establish the $\frac{3}{4}$ " minimum gap required in Step 2B.

- a. For an air suspension system, place a $\frac{3}{4}$ " board on top of the tires after the air has been let out of the airbags (Figure 2). Place the fender on top of the board.
- b. For a spring suspension system, add $\frac{3}{4}$ " to the measurement from Step 2A.

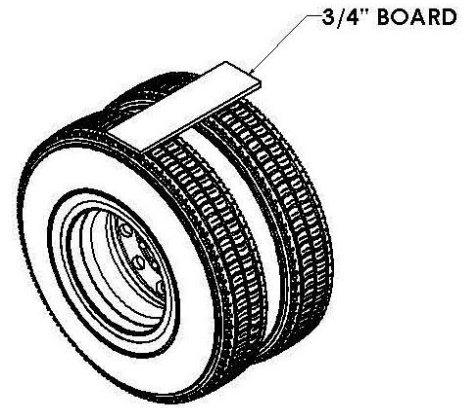

Figure 2

STEP 3

- A. Position the fenders exactly where they will be mounted.
 - a. Visually pick and mark the locations that the brackets will attach to the frame.
- B. It is possible to bolt a plate (not supplied) to the frame and weld the brackets to that plate (Figure 3). Another option is to weld the bracket directly to the frame.
 - a. Plate should be a minimum of $\frac{1}{4}$ " thick steel.

Tip: Check owner's manual before welding directly to the frame. Most manufacturers do not suggest welding anything directly to the frame.

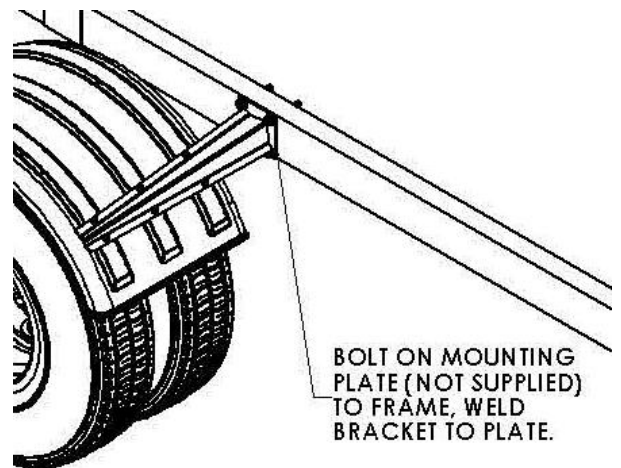

Figure 3

NOTE: Depending on the length of the truck frame and the placement of the mud flap hangers, the fender may tuck inside the mud flap hanger. Figure 4 shows a truck with flaps and fenders.

NOTE: Do not drill into the weld or any other part of the light box. If a mud flap is mounted to the light box style fender and the mud flap is backed over, it may cause the interior welded plate to become loose. Slot the mud flaps to prevent this issue. This is NOT covered under warranty.



Figure 4

- C. If possible, position the mounting brackets so they are located within 15" of the bottom of the fender. This protects against wind blowing the leading edge of the fender back into the tire (Figure 5).

Tip: If the front fender bracket is mounted higher than 15", refer to: <http://www.minimizer.com/instructions.html> for further suggestions on adding additional support.

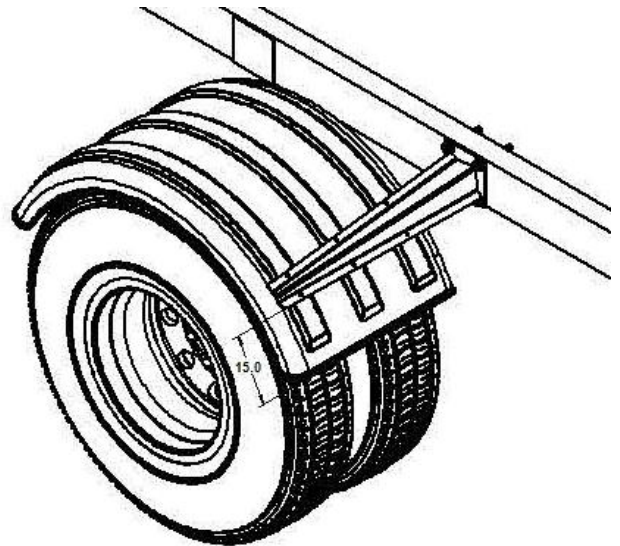

Figure 5

STEP 4

- A. Attach the bracket (PB5010) to the fender.
- Drill six 5/16" holes through the fender using the holes in bracket PB5010 as a guide.
 - Install the 5/16" x 1" bolts through the bracket and into the fender.
 - Use six 5/16" fender washers and 5/16" nuts provided with the kit on the underside of the fender.
 - Tighten the fender bolts. **Recommended torque for the 5/16" x 1" bolts is 10-15 ft-lbs.**
 - Make sure the fenders are square and aligned (Figure 6). Twists or bows in the fender will fatigue the material over time.

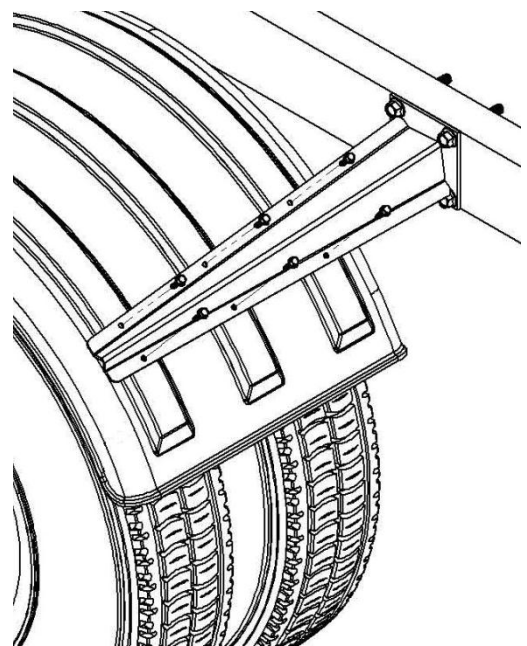

Figure 6

STEP 5

- A. For trucks with air suspension, raise and lower the suspension one final time to confirm that there is adequate clearance between the fenders and wheels.
- B. Recheck all brackets and bolts to ensure they are tightened to the recommended torque.