



B100BTSA

Fender Mounting Instructions for MIN100, MIN150, MIN1600, MIN161200, MIN1900, MIN2200, MIN221800, MIN2260, MIN2480 & MIN9950 Fenders

STEP 1

- A. Unpack all cartons and lay out parts.
- B. Compare the parts with hardware kit B100BTSA as shown in Figure 1.

PART NUMBER	DESCRIPTION	QTY.
PB5052	STAINLESS TUBE LT	4
PB5015	SWIVEL BRACKET BLACK Z(ALONE)	4
I62C450BFL8/RB2FT	5/8"-11 x 4 1/2" HEX FLANGE BOLT	4
I62CNCG/RB2	5/8"-11 CLASS G FLANGE LOCK N	4
PB1/2"SPACER	1/2" POLY SPACER	12
PBRDR111069A	STAINLESS TUBE INSERT BLACK	4
U BOLT	U BOLT OF FOR PB100H	12
STAINLESS STEEL TUBE PLATE	BOLT GUARDS	24
131CNCF/RBZ	5/16-18 CLASS G FLANGE LOCK	24
PB5053	CLAMP FOR FB-5052LT	4
CLAMP BOLT	5/8"-11 X 2 1/8" HEX BOLT	4
CLAMP LOCK WASHER	5/8" LOCK WASHER	4
CLAMP NUT	5/8"-11HEX NUT	4



Figure 1

STEP 2

- A. Measure the suspension travel. This measurement is used to determine the distance between the fender and the wheel.
 - a. For air suspension systems, let the air out of the air bags.
 - b. For spring systems, measure from the stops on the springs to the bottom of the frame.

NOTE: For air suspensions with travel exceeding 6”:

In some cases a travel stop may need to be installed to prevent such large gaps between fenders & tires. This will help with alignment and 5th wheel plate clearance. (Please call Minimzer @ 800-248-3855 for questions regarding this issue).

- B. Gap the fenders $\frac{3}{4}$ ” over the maximum travel point of the suspension system. The goal is to make sure the fender does not rub on the tire. A gap larger than $\frac{3}{4}$ ” may be necessary if using worn tires.

TIP: Establish the minimum gap required in Step 2B.

- a. For an air suspension system, place a $\frac{3}{4}$ ” board on top of the tires after the air has been let out of the airbags (Figure 2). Place the fender on top of the board.
- b. For a spring suspension system, add $\frac{3}{4}$ ” to the measurement from Step 2A.

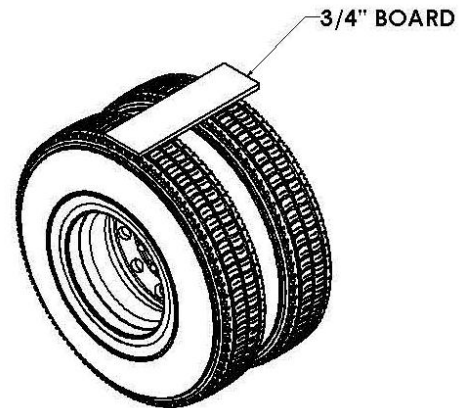

Figure 2

STEP 3

- A. Position the fenders exactly where they will be mounted.
 - a. Visually pick and mark the locations that the brackets will bolt or weld to the frame (depending on mounting kit).
- B. Try to use existing holes in the frame to bolt through. It is possible to remove any existing frame bolt and replace it with the supplied bolt in the bracket kit.



Tip: It is common for the front bracket to align with the existing quarter fender holes and the rear bracket to align with the holes left from the mud flap hanger.

NOTE: Depending on the length of the truck frame and the placement of the mud flap hangers, the fender may tuck inside the mud flap hanger.

NOTE: Do not drill into the weld or any other part of the light box. If a mud flap is mounted to the light box style fender and the mud flap is backed over, it may cause the interior welded plate to become loose. Slot the mud flaps to prevent this issue. This is NOT covered under warranty.



- C. Spacers are supplied to bring the steel swivel away from the frame in the event of any obstructions (Figure 3).
 - a. The ideal setup is to mount the steel swivel directly to the frame.

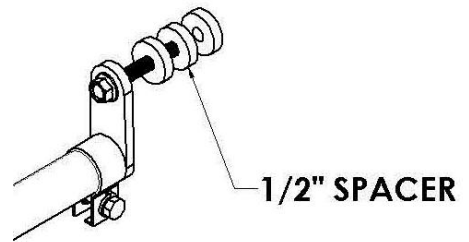

Figure 3

NOTE: Use spacers only when necessary.

- D. If possible, position the brackets on the leading edge of the fender are within 15" of the bottom of the fender to avoid wind blowing the fender back into the tire. (Figure 4).

Tip: If the front fender bracket is mounted higher than 15", refer to <http://www.minimizer.com/instructions.html> for suggestions on adding additional support.

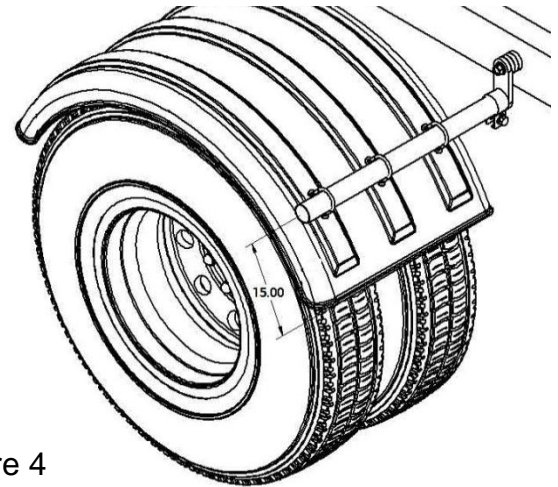

Figure 4

STEP 4

- A. Slide the stainless clamp (part number PB5053) and the mounting tube (part number PB5052) onto the steel swivel (part number PB5015).

Place plastic end cap (PBRDR111069A) into the end of the mounting tube (Figure 5).

Tip: Make sure the slot on the mounting tube is facing down towards the ground.

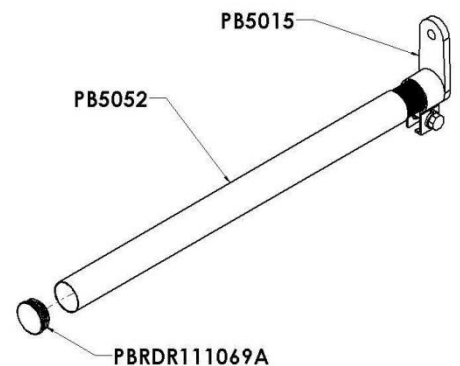

Figure 5

STEP 5

Once the brackets are placed in position with the fender, tighten the 5/8" x 4-1/2" bolts that attach the PB5015 steel swivel to the frame (Figure 6). **Recommended torque is 160-170 ft-lbs.**

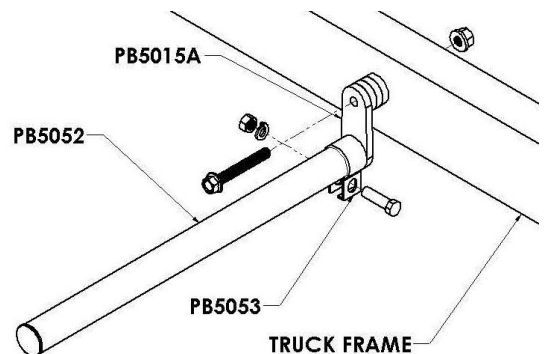

Figure 6

STEP 6

Position the tube clamp 1/4" away from the end of the stainless tube. Next, tighten the tube clamp (PB5053) to lock the mounting tube in place. **The recommended torque for the clamp is 30 ft-lbs.** Figure 7 shows an example over-tightened

tube clamp and Figure 8 shows a properly tightened tube clamp. **Over tightening the tube clamp will cause the clamp to make uneven contact and cause the tube to loosen up over time.**



Figure 7

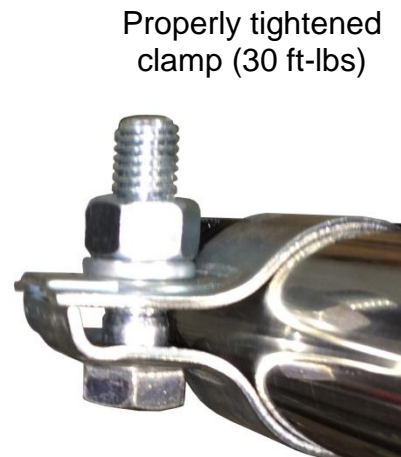

Figure 8

STEP 7

A. Attach the bracket (PB5052) to the fender.

- a. Drill six 5/16" holes through the fender using the holes in the fender washers as a guide.
- b. Install the 5/16" x 2 1/2" x 3 1/2" U-bolts through the bracket and into the fender.
- c. Use two fender washers per U-bolt.
- d. Place one washer on the inside and outside of the fender. Use three U-bolts per fender bracket tube.
- e. Tighten the U-bolts. **Recommended torque is 75-90 in-lbs. Do not exceed recommended torque.**
- f. Make sure the fenders are square and aligned (Figure 9). Twists or bows in the fender will fatigue the material over time.

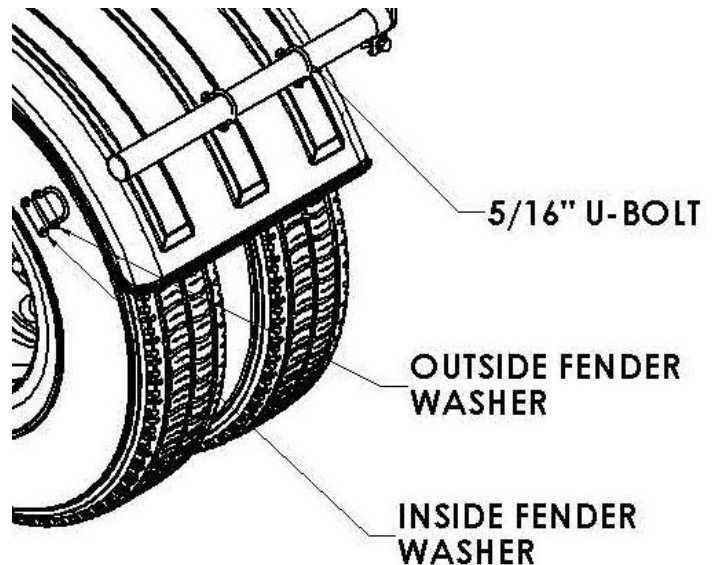

Figure 9

STEP 8

A. For trucks with air suspension, raise and lower the suspension one final time to confirm that there is adequate clearance between the fenders and wheels.

NOTE: ONCE FENDERS ARE IN SERVICE, OCCASIONALLY CHECK TORQUE ON THE 5/8" X 4-1/2" HEX BOLTS IN THE FRAME TO MAKE SURE THEY DO NOT LOOSEN OVER TIME.