



## B4578WOA

### Fender Mounting Instructions for MIN4000, MIN900, MIN1500 & MIN1554 Fenders

#### STEP 1

- A. Unpack all cartons and lay out parts.
- B. Compare the parts with hardware kit B4578WOA as shown in Figure 1.

PART NUMBER	DESCRIPTION	QTY
PB5010	STEEL WELD-ON TAPERED BRACKET	4
I31C100BSF/RBZ	5/16-18 X 1 HEX WASHER HEAD BL	24
I31CNCF/RBZ	5/16-18 CLASS G FLANGE LOCK	24
I31N150WFEZ	5/16 X 1 1/2 FENDER WASHER	24
PB5067	STEEL ANGLE FOR PB5069	2
I62C250BFL8/RBZ	5/8-11 X 2 1/2 HEX FLG BOLT BZ	2
I62CNCG/RBZ	5/8-11 CLASS G FLANGE LOCK N	2
PB1/2"SPACER	1/2" POLY SPACER	2
PB5069	COMPOSITE CENTER BRACKET	2
I31C125BSF/RBZ	5/16-18 X 11/4 HEX WASH HEAD B	8
I31CNCF/RBZ	5/16-18 CLASS F FLANGE LOCK	8
PB5071	COMPOSITE ANGLE FOR PB5069	2
I31C125BSF/RBZ	5/16-18 X 11/4 HEX WASH HEAD B	14
I31CNCF/RBZ	5/16-18 CLASS F FLANGE LOCK	14
I31C100BSF/RBZ	5/16-18 X 1 HEX WASHER HEAD BL	8
I31CNCF/RBZ	5/16-18 CLASS F FLANGE LOCK	8
I31N150WFEZ	5/16 X 1 1/2 FENDER WASHER	16



Figure 1

#### STEP 2

- A. Lay the fenders out and clamp them together (Figure 2). This will make bolting them together much easier.

Figure 2



- B. Bolt the fenders together. A pack of 5/16 x 1" bolts, 5/16" nuts and 5/16" x 1- 1/2" fender washers is included in the kit. **Use four bolts per joint and torque bolts 10-15 ft-lbs.**

### **STEP 3**

- A. Measure the suspension travel. This measurement is used to determine the distance between the fender and the wheel.
- For air suspension systems, let the air out of the air bags.
  - For spring systems, measure from the stops on the springs to the bottom of the frame.

**NOTE: For air suspensions with travel exceeding 6":**

In some cases a travel stop may need to be installed to prevent such large gaps between the fenders & tires. This will help with alignment and 5<sup>th</sup> wheel plate clearance. (Please call *Minimizer @ 800-248-3855* for questions regarding this issue).

- B. Gap the fenders 3/4" over the maximum travel point of the suspension system. The goal is to make sure the fender does not rub on the tire. A gap larger than 3/4" may be necessary if using worn tires.

**TIP:** Establish the 3/4" minimum gap required in Step 3B.

- For an air suspension system, place a 3/4" board on top of the tires after the air has been let out of the airbags (Figure 3). Place the fender on top of the board.
- For a spring suspension system, add 3/4" to the measurement from Step 3A.

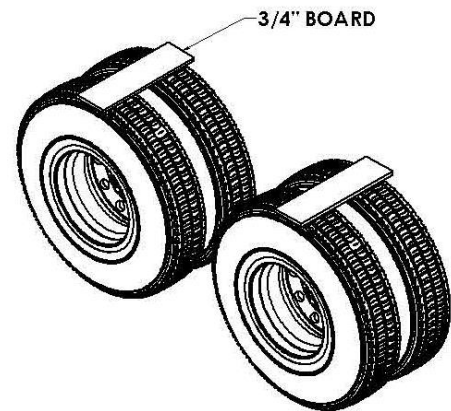

Figure 3

### **STEP 4**

- A. Position the fenders exactly where they will be mounted.
- Visually pick and mark the locations that the brackets will attach to the frame.
- B. It is possible to bolt a plate (not supplied) to the frame and weld the brackets to that plate (Figure 4). Another option is to weld the bracket directly to the frame.
- Plate should be a minimum of 1/4" thick steel.

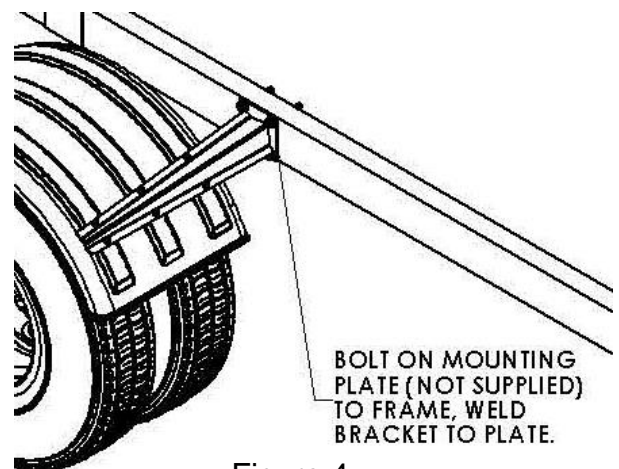

Figure 4

**Tip: Check owner's manual before welding directly to the frame. Most manufacturers do not suggest welding anything directly to the frame.**

**NOTE:** Depending on the length of the truck frame and the placement of the mud flap hangers, the fender may tuck inside the mud flap hanger. Figure 5 shows a truck with flaps and fenders.

**NOTE:** Do not drill into the weld or any other part of the light box. If a mud flap is mounted to the light box style fender and the mud flap is backed over, it may cause the interior welded plate to become loose. Slot the mud flaps to prevent this issue. This is NOT covered under warranty.



Figure 5

C. Install center bracket assembly (Figure 6).

- a. Try to use existing holes in the frame to bolt through. It is possible to remove any existing frame bolt and replace it with the supplied bolt in the bracket kit.  
**Recommended torque for the 5/8 x 2-1/2" bolt with washer is 110-115 ft-lbs.**

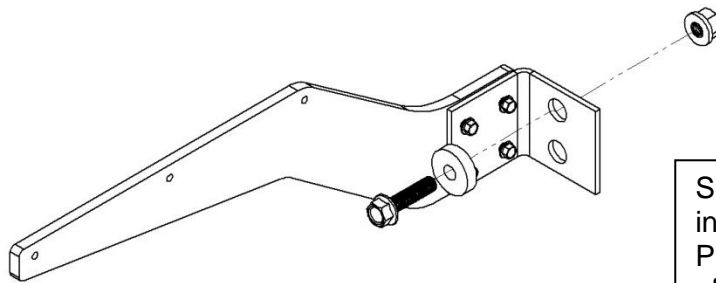

See IMPORTANT assembly instructions for center bracket PB5069 & PB5067, last page of this form.

Figure 6

D. Install center bracket as close to where the two fenders join together as possible (Figure 7).

- a. Drill three 5/16" holes through the fender using the holes in bracket PB5069 as a guide.
- b. Use three 5/16" x 1 1/4" bolts to bolt the center bracket and fender together.
- c. Use 5/16" fender washers and 5/16" nuts provided with the kit on the inside of the fender. **Recommended torque for all 5/16" hardware is 10-15 ft-lbs.**

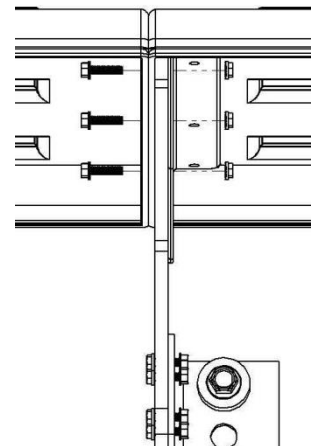

Figure 7

E. Some installations may not allow the center bracket to bolt through the end of the fender.

a. In these cases use the plastic angle (PB5071) to connect the fender to the center bracket assembly (Figure 8).

b. Use three 5/16" x 1" bolts, washers, and nuts to bolt PB5071 to the center bracket assembly. Do not tighten these until the fender is level. **Recommended torque is 10-15 ft-lbs.**

**Tip:** PB5071 is also used as a height adjustment for the end of the fender.

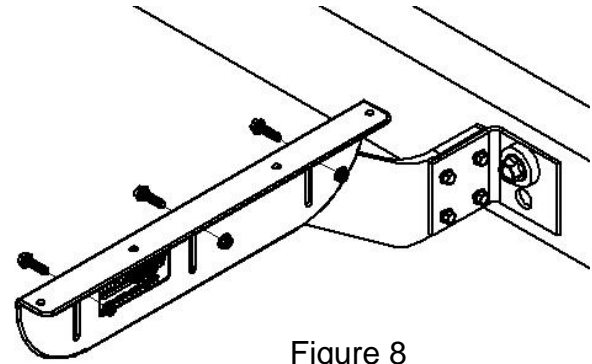

Figure 8

F. Drill four 5/16" holes through the fender using the holes in bracket PB5071 as a guide (Figure 9).

a. Install the 5/16" x 1 1/4" bolts through the bracket and into the fender.

b. Use 5/16" fender washers and 5/16" nuts provided with the kit on the underside of the fender. **Recommended torque is 10-15 ft-lbs.**

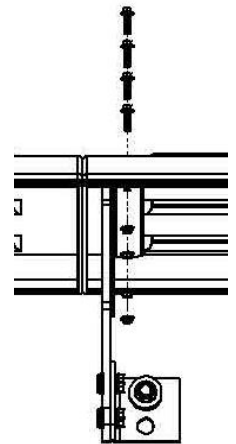

Figure 9

## **Step 5**

A. If possible, position the mounting brackets so they are located within 15" of the bottom of the fender. This guards against wind blowing the leading edge of the fender back into the tire (Figure 10).

**Tip :** If the front fender bracket is mounted higher than 15", refer to <http://www.minimizer.com/instructions.html> for further suggestions on adding additional support.

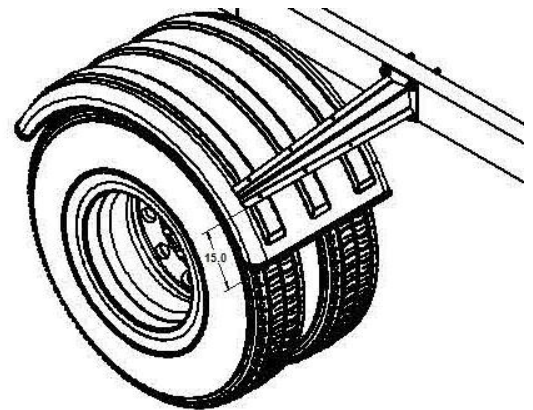

Figure 10

## **STEP 6**

- A. Attach the bracket (PB5010) to the fender.
  - a. Drill six 5/16" holes through the fender using the holes in bracket PB5010 as a guide.
  - b. Install the 5/16" x 1" bolts through the bracket and into the fender.
  - c. Use six 5/16" fender washers and 5/16" nuts provided with the kit on the underside of the fender.
  - d. **Tighten the 5/16" bolts. Recommended torque is 10-15 ft-lbs.**
  - e. Make sure the fenders are square and aligned (Figure 11). Twists or bows in the fender will fatigue the material over time.

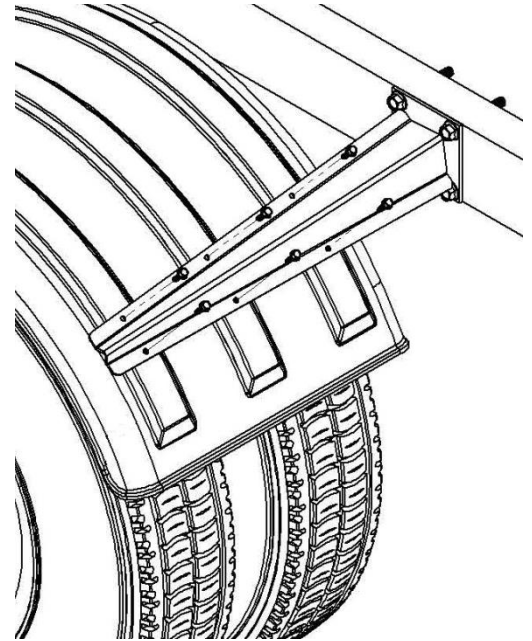

Figure 11

## **STEP 7**

- A. For trucks with air suspension, raise and lower the suspension one final time to confirm that there is adequate clearance between the fenders and wheels.

REVISIONS				
ZONE	REV	DESCRIPTION	DATE	APPROVED

**IMPORTANT INFORMATION**

Assemble a left hand and right hand arm assembly as shown. The bolt head (MUST) be on the metal plate side. The serration on the bottom of the bolt head will damage the plastic arm. Use the nut on the plastic arm side. Tighten from the bolt head side so the nut does not spin on the plastic arm. If the locknut is ever loosened after it has been tightened it is highly recommended to replace the locknut.

**RECOMMENDED TORQUE FOR ALL 5/16 HARDWARE IS 10-15 FT-LBS**  
**CAUTION: OVERTIGHTENING THE HARDWARE WILL DAMAGE THE PLASTIC ARM AND COULD CAUSE IT TO FAIL**

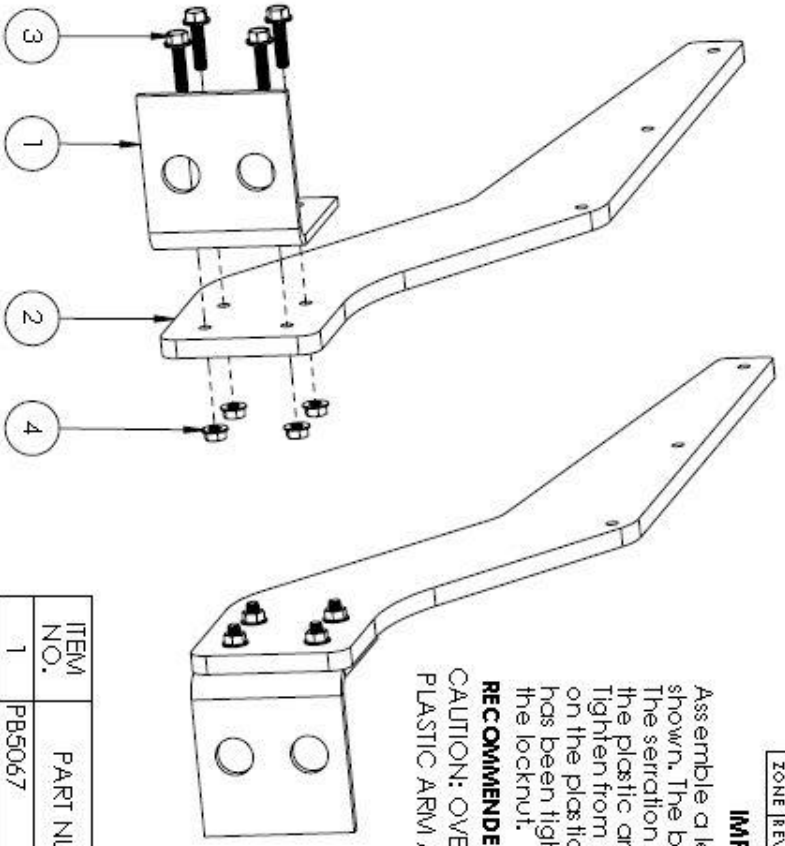

ITEM NO.	PART NUMBER	DESCRIPTION	QTY.
1	PB5067	BRKT,5067STL,CNTR,ANGL	2
2	PB5069	BRKT,5069,PE,CNTR,.5	2
3	I31C125BSF/RBZ	HDWR,HHCS,RBZ,SERR,5/16-18X1.2	8
4	I31CNCF/RBZ	HDWR,NUT,RBZ,FLNG-LOOK,5/16-18	8

DESIGN BY:	DATE:	UNIT OF MEASURE:	SHEET NO.:	TOTAL SHEETS:
BAG	3/29/2016	INCHES	A	1
CONTR BY:	TRAP	DRAWING SCALE:	SCALE:	WEIGHT:
	REFER TO PRINT	1:1	1/4	N/A
CONTR BY:	SOURCE:	ANGULAR DIMENSIONS:	SCALE:	WEIGHT:
		ONE PLACE DECIMAL: 30°	1/4	N/A
		TWO PLACE DECIMAL: 45°	1/4	N/A
		THREE PLACE DECIMAL: 60°	1/4	N/A
		FOUR PLACE DECIMAL: 90°	1/4	N/A
		FIVE PLACE DECIMAL: 120°	1/4	N/A
		SIX PLACE DECIMAL: 150°	1/4	N/A
		SEVEN PLACE DECIMAL: 180°	1/4	N/A
		EIGHT PLACE DECIMAL: 210°	1/4	N/A
		NINE PLACE DECIMAL: 240°	1/4	N/A
		TEN PLACE DECIMAL: 270°	1/4	N/A
		ELEVEN PLACE DECIMAL: 300°	1/4	N/A
		TWELVE PLACE DECIMAL: 330°	1/4	N/A
		THIRTEEN PLACE DECIMAL: 360°	1/4	N/A

**SPRAY CONTROL SYSTEMS INC.**  
 BLOOMING PRAIRIE, MN 55917  
 DESCRIPTION:  
 PLSTC, CNTR, BRKT, ASSY, INSRT

PRINTING INSTRUCTIONS